

PRE-MILLENNIUM TENSION

A Role Playing Scenario By Richard Love
PlayTesters: Bevan, Dave, Brendon, Greg, Lyndon.

PRE-MILLENNIUM TENSION

Tonight, the grey skies will part to reveal the gate into heaven. Today is the 31st of December 1999. Tonight, the four winds of the earth will cease to blow. Today is the last day on earth. Tonight, the holy city of New Jerusalem descends from God. Today the world ends.

The characters in Pre-Millennium Tension are all members of an apocalyptic cult the Pilgrims to the Descended City that have gathered on the eve of the new millennium. They have chosen to witness the end of the world from an old movie-set, which lies abandoned in the desert.

In 1969, at the close of the era of massive Hollywood Westerns, Californian executives plotted an ambitious movie. It was to feature a cast of stars and an horrifically violent, climatic showdown, in which government troops closed in and massacred the starring outlaws. It was anti-Western. Town, the government, the East would triumph over the empty vastness of the West and the outlaws. The film would have been dazzling. The film would have been "Armageddon".

Unfortunately, an actors strike, a bankruptcy in Los Angeles, and a budget blow-out prevented the completion of the film "Armageddon".

All that remains is a few hundred meters of decaying celluloid and the movie set itself. The set was built in a canyon at the foot of the soaring San Juan Mountains, far from real towns and cities. A few buildings, the Saloon, the Bank and the Railway Station still stand.

Today, it is thirty years later. Armageddon is again approaching. This time the world ends...for real.

Contents

PRE-MILLENNIUM TENSION	2
Contents	3
Game-Master's Information	3
Background Information	3
Themes	4
Rules	4
Starting the Game	5
Reading the Scenario	5
Player Characters	6
Character Descriptions	6
Character Summaries for the GM	6
Dave Krash	7
Kurt Thompson	9
The Magus	11
Soviet	13
Jack Burroughs	15
Scenes and Personalities	17
Timeline of Events	17
Arrival at Armageddon and Gun Fight With The C.R.P.L.	18
Exploration of Armageddon	19
Discussions with C.R.P.L. Survivors	22
Inspection of Dead US Air Force Personal.	23
The Attempt to Break into the Bank Vault.	23
A Clash with an Air Force Patrol.	24
Exploring the Underground Complex.	25
Contacting the FBI Agents.	27
The Final Battle For Armageddon.	28
The End	29
Resources	30
Map of Armageddon.	30
The Town of Armageddon.	31
The Road to Armageddon.	32

Game-Master's Information

Background Information

The idea of this scenario, for five players and one GM, is simple. The players are mad cultists (the Pilgrims to the Descended City) and they are holed up in

an abandoned movie set, awaiting Armageddon. The game is a cross between a Western and an Occult Thriller. Couldn't be simpler?

Well, there are some complicating factors. First there are the characters. Dave Krash is a Gulf War veteran and is the leader of the cult. He had a revelation in the Syrian Desert. Then, there's Kurt Thompson, another Gulf War veteran and Dave's enforcer. Not as lucky as Dave, Kurt's got a plate in his head. Next is Soviet, a deranged computer geek. She's the technical officer for the cult and secretly believes she is a soviet sleeper agent planted during the collapse of the USSR, to cause havoc in America. Jake Burroughs an early recruit to the cult is really a government informant, a spy placed to watch over the cult. Then there is The Magus, the cult sorcerer, who believes that he is an ancient Indian shaman possessed by an evil spirit.

To further complicate matters, the site the cult has chosen, the abandoned movie set, happens to be built over a US Military weapons cache. (There's a lift in the vault of Bank.) Well, actually the movie set was always a front for the weapons cache. It was built during the height of the Cold War, when man was about to land on the moon and American troops were still in Vietnam. Paranoid, about the possible surveillance capabilities of the various Sputniks spinning overhead in space, Pentagon planners devised the ruse of building a weapon storage facility in the desert disguised as the activities of a movie production. After the construction was complete, the production company was allowed to fall into bankruptcy and quickly the site faded from public memory. The weapons cache is still in use. It is being used to store a number of warheads carrying a payload of weaponised small pox. A couple of air force police are on duty in the Bank at any one time.

The final complicating factor is that just prior to the arrival of the cult, a group of terrorists (members of the Cattle-Ranchers Protection League), intent on capturing a warhead, attacked the facility- killing the air force guards. As the cult arrives in Armageddon, the terrorists are trying to break open the vault, and gain access to the lift.

Themes

The scenario is meant to have the trappings of a Hollywood Western. The characters are Pilgrims guided to this place by an Indian mystic, many of the weapons and locations may be recognisable as staples of the western era and like the film characters the player characters are destined to die in a hail of bullets. The scenario is a "weird-western" as long as the GM concentrates on evoking the "west", the "weird" should sort itself out.

Rules

This scenario is intended to be run as a single three-hour session, at a convention, perhaps. It requires five players and one GM. It is quite light on rules. The game should be run in a narrative style with the players describing

the actions of their characters to each other, and to the GM; with minimal interference from either the GM or any rules set. To aid the players to do this, each character description includes some hints about the character's capabilities, for example, Kurt Thompson is *excellent at using and maintaining personal military weapons*. As long as a player is consistent with these guidelines the GM should not need to be too involved in rules adjudications. Perhaps, the occasional dice roll (high numbers good) should be made when the result of an action is in doubt (and also helps to keep dice dependent players happy).

In fact, the only points that the GM should enforce is the timing of actions to avoid inconsistencies with the scenario timetable of events, for example, it should take the characters at least an hour or two to break into the vault in the Bank.

A table of all characters' capabilities is provided for the GM, on page 6. Of course, if the GM prefers they may use the information provided to generate the scenario's characters using their favourite game system.

Starting the Game

It is suggested that the GM begins the session by reading out the introduction on page 2. The GM should then hand out the character sheets and allow the players time to read the backgrounds and familiarise themselves with their characters. At this point the GM may want to explain either the rules above, or whatever alternative system they wish to use. It may also be an idea to quickly go over each character with the relevant player, away from the group, to make sure that the player understands who their character is and what they are trying to do.

The first scene is the arrival of the characters in Armageddon. It is suggested that the GM wears a cowboy hat.

Reading the Scenario

The GM should thoroughly read this scenario before attempting to play it. There are three major sections. The first section contains the descriptions of the **Player Characters**, each player should receive a copy of their character at the beginning of the game. Each description contains a character background and a description of the character's capabilities and major possessions. The second section, **Scenes and Personalities**, contains just that, a timeline of events that occur during the scenario, scenes that may occur and the personalities that the characters may interact with. Finally, **Resources**, contains maps and photographs of Armageddon.

Player Characters

Character Descriptions

David Krash is in his 40s. He has wild straggly hair and is dressed like a cattle rancher.

Kurt Thompson is in his mid 30s, he has a close-cropped military-style haircut. Kurt is very big and strong. He is dressed in combat fatigues and has a lot of weapons.

The Magus is an elderly, wrinkly, American Indian. He is bald, and dressed in a deep red, hooded robe.

Soviet is a young, surly looking woman in her 20s. She is dressed in the style of a Soviet military commissar.

Jack Burroughs is a fit man in his late 20s. He is dressed, like David, as a cattle-rancher.

Three other Pilgrims travelling to Armageddon are Peter, Paul and Judas. They are dressed like cattle-ranchers, too.

Character Summaries for the GM

Dave Krash

David has an *above average constitution*. He has *the ability to use and maintain personal military weapons and systems* and he has *excellent survival skills*. David is a *strong leader with a religious fervour*.

Kurt Thompson

Kurt is *strong* and has an *indomitable constitution*. He has *suffered severe head trauma, which makes it difficult for him to concentrate on complex tasks*. Kurt is *excellent at using and maintaining personal military weapons*. He is *very loyal to David*.

The Magus

The Magus has a *super-human strength and endurance* and to his lasting regret is *immortal*. He is *reluctant to use these abilities openly*. The Magus has *extensive knowledge of the occult*.

Soviet

Soviet is *intelligent*. She is *prepared to sacrifice herself for the cause (the soviet cause)*. Soviet *can use computers* and she has had *weapons training*.

Jack Burroughs

Jack Burroughs is *agile and of above average intelligence*. He is *skilled in infiltration* and has had *weapons training*.

Dave Krash

The Sermon.

We were willing servants and slaves to darkness alike. We were in the employ of the Devil. It was the year of our Lord, nineteen hundred and ninety one. We were lost in the deserts of Babylon. My skin was blistered and my lips cracked. I shared the last of my water with the barely conscious Kurt. We moved only at night and by day we hid in the shadow of the dunes and lay listening to the distant thunder of artillery.

Kurt and I were Airborne Rangers, our squadron had infiltrated far into the Iraqi desert. Our mission had been to laser illuminate targets: radar sites, tanks, anti-aircraft batteries. Once illuminated, cruise missiles, launched from distant ships or high altitude B-52s, would rain down fiery malevolence.

The instruments of the devil were not precise. One day, the death we summoned from the skies fell down upon our own squadron. Four of my men were killed in the strike. The rest killed in a fractured firefight with the nearby Iraqi soldiers. The muzzles flashes of our weapons blasted through the evening desert, strobes in a discothèque of the dead and dying. A second missile crashed down. The Iraqis screamed in tangle of blood and limbs and burning flesh. Kurt and I were the only survivors, and Kurt had taken a bullet in the head.

Struggling with his weight, I heaved Kurt over my shoulder and walked away from the smoking carnage into the desert. I was cut adrift, abandoned by the Army, and as I wandered I came to look upon this world with strange eyes. The blue sky was cloudless and empty except for the burning white light of the sun and the faint tendrils of vapour left by high altitude jets. At night the horizon glowed, lit by burning oil fields. We could not see the stars.

For forty days and nights we walked, until, in the heat of the day, I saw a city. The ground had opened up I was on the lip of an escarpment overlooking a valley, within which lay the city, green and irrigated with low pale buildings. Kurt lay at my feet. There was no sign of the war in this oasis. While I stood looking upon the city, the marvellous creation, gritty sand filled my nostrils and a dry wind parched my throat. The burning sun baked the beads of sweat that drained the fluid from my body. Tried by the elements, I awaited the Herald of God, for truly this was the city of God, New Jerusalem, descended from heaven.

I was not forsaken. Out of the valley arose an angel. Slowly it moved towards me. Black and insectoid, it had an horrific visage. Huge, shinny eyes stared at me as it hovered upon whirring wings, which flickered above its

abdomen. Silhouetted by the sun the angel hovered before me and with a voice short and staccato, it spoke:

“D.David..before..you..lies...the...ci.city....of.your....your...L..Lord...God...our..f.fat her...in..heaven...above...You...are..ch.chosen..amongst...all..your..people..t.to..witn ess..the..g.glory..of...God...b.before..Judgement..befalls....On...t..the..last..day.a...w ar...will..be..fought...Fight...well..or..all..that....you.see..before....you..beaut.i..ful.. Jerusalem...will..have..never...been.”

With a gasp, the valley closed, New Jerusalem disappeared, but the angel did not. The light from the sun, behind it, diffracted, shimmered and bent and a Blackhawk helicopter hung in the air. Kurt and I were saved. Saved by God.

It is now December 31, 1999. The end times are upon us. My followers (the Pilgrims to the Descended City) and I are about to arrive at Armageddon where we will await the descent of New Jerusalem.

CHARACTER SHEET: Dave Krash

David has *an above average constitution*. He has *the ability to use and maintain personal military weapons and systems* and he has *excellent survival skills*. David is a *strong leader with a religious fervour*.

Equipment: David is armed with a Colt 1873, 0.45 calibre revolver. It has a chamber that holds 6 bullets. It is loaded and David has an additional 12 bullets with him. David is wearing jeans, boots, shirt and a stockman's coat.

Character Goals:

David's goal is to survive with his followers until New Jerusalem descends from heaven. He also wants to destroy the citizens of Babylon and the Instruments of Satan, which includes the US military who abandoned him in the desert.

Opinions:

Kurt Thompson: Was under David's control during the Gulf war. David carried him to New Jerusalem. He is very loyal to David and David is aware that he is very heavily armed.

Natchenko: "The Magus": David was guided to him, by an angel, soon after returning from the Gulf War. David often turns to him for spiritual advice. He has chosen here as the site for the cult to await Armageddon.

Jack Burroughs: One of David's early followers. He is quite an orator and David suspects he may be vying for leadership.

Soviet: David thinks her a weird girl. She is a recent recruit and runs a website for the Pilgrims of the Descended City.

Kurt Thompson

David is boss. He is the Sergeant. When we were in the Gulf he was the one that got us out alive, him and God. You should not believe everything you see on the t.v. about the Gulf.

We were Airborne Rangers, 1st Company, 2nd Squadron. Our mission was to sneak into Iraq with laser guns. Now, these were not Star Wars lasers, they had no red lights or much heat. Our task was to shine lasers on bunkers, hangers, whatever. Then missiles in the sky would see the laser spot and fly down and destroy what we were shinning the laser at.

One day, everything went to shit. First a missile went off target and landed on us instead of the tank we were shinning the laser at. That killed Matthew, Mark, Luke and John.

Then the Iraqis came out of their tanks and machine-gunned our squad. Their tracers lit up the evening desert. We returned fire. Pretty much everyone was dead, on our side, except David and I, when I saw another missile tear into the ground. I don't remember much after that.

The doctors say I was shot in the head. It is a miracle that I survived.

David and I were the only survivors.

He carried me away from death and into the desert. The army, not wanting to burden themselves with bad news in a good news war, abandoned us. They did not care that we survived, they left us behind. It was God that let me live and God that looked after us in the desert. God and David saved me.

An angel spoke to David in the desert and told him that a war was coming and that the Kingdom of God would descend from heaven.

Then, God sent a helicopter to pick us up in the desert. This is the second miracle.

Since the war David has looked after me and I've looked after him. He is leader of the Pilgrims to the Descended City and I am his bodyguard. I save him from the demons and the government.

It is very nearly the end of the world. The spiritual adviser for the Pilgrims, The Magus, has said that the best place to await the Kingdom of Heaven is an abandoned movie set in the mountains.

It is now December 31, 1999. I am on my way to Armageddon. I've brought plenty of weapons.

CHARACTER SHEET: Kurt Thompson

Kurt is *strong* and has an *indomitable constitution*. He has *suffered severe head trauma, which makes it difficult for him to concentrate on complex tasks*. Kurt is *excellent at using and maintaining personal military weapons*. He is *very loyal to David*.

Equipment: Kurt is wearing military-style camouflage gear. He has a Winchester 1901, 10-gauge shotgun, which has a magazine of 5 rounds. It is loaded and he has a box of 20 shells for it. Kurt also has an aged M-14 7.62mm Assault Rifle (this is an automatic weapon). The clip for this weapon contains 20 bullets and Kurt has five clips for the rifle. Kurt also has (in the trunk of the car) a Soviet 85mm RPG-7 rocket launcher. Kurt has two rockets for the launcher and he is a bit concerned about their reliability.

Character Goals:

Kurt's main goal is to protect David Krash and kill the Instruments of Satan wherever they might lie. The US Military is Babylon and evil.

Opinions:

Sergeant (Dave Krash): Leader of the Pilgrims to the Descended City. He saved Kurt in the Gulf. Kurt is very loyal to the Sergeant.

The Magus: He is the spiritual advisor to the Pilgrims. An angel led the Sergeant to him.

Jack Burroughs: An early member of the Pilgrims.

Soviet: A weird girl who calls herself Soviet. She does stuff with computers, and Kurt believes she has an unhealthy obsession with uniforms and military paraphernalia.

The Magus

The abyss. Cool, dark, oblivion and an eternity of emptiness. The aeons pass without change or motion. The derivative is zero in all directions and times. Within the abyss existence and non-existence are equally nonsensical, both concepts an alien logic. This is the realm of dreams, gods, demons and abstract mathematics, entities devoid of all meaning.

This is where you belong, where you came from, where you will return. You long for the limbo of non-existence and stupor of the unconscious. One thousand rotations of this humid ball of rock and gas around its boiling star have you dwelt here.

Your mother, your father, your midwife, your creator, your god, was a mortal shaman. You were born in a tent. Your first glimpse of the world was of the stars, encircled by canvas and the smoke that wound its way through the chimney-hole in the centre of the tent and out into the night. The shaman capered around you, chanting, his wolf-skin cloak streaming behind. His shadow, multiplied and magnified by the flicking fire, followed his dance upon the walls of the tent. Writhing upon the floor, rolling in your own steaming ichor, your tendrils also moved to the rhythm of the mad Indian's chanting.

How long you lay there you cannot be sure. All of your life, a moment, was spent on the packed earth floor of the tent, lying in the arid smelling smoke-until you made your first conscious move. With a lethargic flick of a pseudopod you became an actor in the drama of life.

The Indian dropped to the floor. Now it was the shadows of your tentacles on the tent wall that flicked and danced. Black shadows dancing in the red light of the flame, oily black tentacles delving amongst the red blood on the floor.

Suddenly, with a rush of air, there was only one body on the floor of the tent. The Indian rose to his feet, but from his eyes you gazed upon the world. You took the Indian's name, Natchenko, and acted as the tribal shaman while you learnt of the world, the beasts, the men, the heat, and the intolerable pain of existence. Once you learnt all you could, you left the tribe, and for the last one thousand years you have roamed the world looking for a way to die.

You have been looking for the way from this world, the path to oblivion and the ladder to the gallows and eventually you found it. You must perform a sacrifice, tonight, at the exact instant that the new millennium begins. You must ritually disembowel a woman on the site of your entrance to the world, and in her blood will be found the blood of all the prophets and of all the

saints and of all that were slain upon the earth and in the stench of this corruption you too will cease to be.

In recent years you have found a mortal named Dave Krash, a madman leading a group called the Pilgrims to the Descended City. The cult has accepted you as their spiritual guide, their shaman, and you have directed them to the place in the desert where you were born. This, you have told them, will be the site at which New Jerusalem will descend from heaven, the world will end and the chosen will enter the Kingdom of God.

The tent in which you were born is long gone, and has been replaced by the set for a Hollywood western. Aptly named "Armageddon", the film bankrupted the producers and was never finished. Now twenty years later Armageddon will conclude, the world will end (for you at least), and not a single camera will record it.

It is now December 31, 1999. The end of time is upon you. Yourself and the other Pilgrims to the Descended City are about to arrive at Armageddon.

CHARACTER SHEET: The Magus, Natchenko

The Magus has *a super-human strength and endurance* and to his lasting regret *is immortal*. He is *reluctant to use these abilities openly*. The Magus has *extensive knowledge of the occult*.

Equipment: The Magus is wearing red robes beneath which is concealed a sacrificial dagger.

Character Goals:

The Magus' goal is to sacrifice a woman at the site of his incarnation upon the earth. This sacrifice must occur at the beginning of the millennium exactly. The GM will indicate where this location is. Obviously, the Magus needs to ensure that a woman (Soviet, probably) survives until the time of the sacrifice.

Opinions:

Dave Krash: He is a Gulf War veteran and the leader of the Pilgrims to the Descended City. He often asks the Magus for spiritual advice.

Kurt Thompson: Another Gulf War vet. Somewhat disturbed due to a head wound. He is very loyal to Dave.

Jack Burroughs: An early recruit into the Cult.

Soviet: A recent recruit. She acts as webmaster for the cult. She is the Magus' intended sacrifice.

Soviet

my name is soviet. well maybe not, but it's as good as i'll tell you. soviet will do. i am her most days anyway. you see, my name is my soul, my goal, my occupation. i am a weapon of the cold war. no, not a robot. not a tacky hollywood terminator. i am a much more subtle weapon than a ambulatory gun.

i was born in the final years of the 1970s. the cold war was on. the americans had withdrawn from vietnam and we had not yet lost afghanistan; it was heady days in the kremlin, or so i'm told. and so i was born a baby girl of the state. my flesh parents? who knows. maybe political sent to siberia? we were not told much about our genesis. we were kept in a camp. we dressed like american children, our tutors spoke only american "english". we studied american technology, american computers, pcs, arpanet.

but then, the soviet union crumbled around us. we were summoned for our first mission. our only mission, our lifetime mission. you see they had not really been heady days into which we were born. they were the days of the pessimist. the end had been foreseen. the americans may have lost vietnam, but their weapons, their readiness to bomb a country back to the dark ages, their drugged armies of conscripts, their assimilatory culture, their strategic invulnerability, their behemoth economy: all this demonstrated to our "parents" that the soviet union would die, the america eagle would consume the bear, or at least harass and peck it to death like a vulture.

we were the insurance policy. all men want to be immortal and our masters were men. in a land where religion and the afterlife were condemned as capitalist social controls, we were the only hope after death. we were the soviet union version two in embryo. as gorbachev was arrested and the дума placed under siege we were loaded into submarines. our masters were long-term planners. unlike the american leadership they did not have to constantly worry about the next election, sticking only to campaigns that would see fruition within their term, or even within their lifetime. the plan for us was to rebuild the empire. the fall had been planned for.

the submarines surfaced at various points off the coast of the US. some may have been turned back by american hunters. ours got through. we washed up on a deserted beach, in our scuba gear, with our new american identities. our mission is to disrupt. to cause havoc in america, to allow the empire to rebuild without intervention from abroad. to turn the americans isolationist, to cause them to abandon the UN. to bring anarchy to the US.

some of my companions (we have not met again since that first morning on the american beach) have tried to disrupt on a small scale. they enrolled in schools, then shot their teachers and classmates, blaming their actions on death metal, computer games or movies. they hoped to shock a nation into a regime of censorship and oppression. others are mounting divisive, aggressive campaigns; anti-abortion or pro-choice, anti-globalisation, anything to prod the nation into rebellion.

i was assigned religious cults. namely the "Pilgrims of the Descended City" it is lead by Dave Krash, a veteran from the gulf war. it is anti-government and believes that the millennium will usher in an apocalyptic war which will result in the descent from heaven of the kingdom of god.

i am webmaster for the cult. and these are the final days. the cult has chosen an abandoned movie set for a western named "armageddon" to await the end of the world. but it isn't a movie a set. i've seen photographs of this site before, while in mother russia. it is a weapon dump. we received briefings about it. there is an underground complex. maybe, i really can cause armageddon here and now (at least for the ameicans). this will give the motherland, the bear, an opportunity to rise again back home. then the plan will have succeeded. then there will be an afterlife for the nation of atheism.

i am on my way to Armageddon, it is now December 31, 1999.

CHARACTER SHEET: Soviet

Soviet is *intelligent*. She is *prepared to sacrifice herself for the cause (the soviet cause)*. Soviet can use computer systems and she has had *weapons training*.

Equipment: Soviet has a laptop computer and a cellphone/modem.

Concealed in the laptop bag is Derringer 11mm. It has a magazine that can hold one bullet. It is loaded and she has another 5 bullets for it. Soviet is wearing a commissar's uniform.

Character Goals:

Soviet wants to cause disruption to the United States of America. Possibly, the supposed underground weapons complex may be helpful in this regard.

Opinions:

Dave Krash: David is the leader of the Pilgrims to the Descended City and a Gulf War veteran. He is driven and seems to be totally insane, to Soviet- but she is prepared to go along for the good of the USSR.

Kurt Thompson: Another Gulf War veteran, who suffered some kind of head trauma. Kurt is loyal to Dave and carries a lot of weapons.

"The Magus": Soviet thinks that the Magus is strange and spooky. He always seems to be watching her, although it is hard to tell with his cloak pulled over his eyes.

Jack Burroughs: The most normal of the other members of the cult. Soviet cannot quite understand what he's doing with the others, she suspects that he may also have some ulterior motive for joining the cult.

Jack Burroughs

My name is Jack Burroughs and I've been in this loony cult "The Pilgrims to the Descended City" for a few years now, and today is apparently the date of the Descent. Of course Jack Burroughs is not my real name. No. My real name is Albert Duncan, special agent of the Federal Bureau of Investigation. My mission is surveillance, to ascertain what the cult is doing. The idea is to see if they're going to all get totally drunk and wasted like normal people, or maybe they're going to burn down the town, steal a nuke, bomb a crowded kindergarten, assassinate the President something like that. If so I am to intervene and take whatever steps I deem necessary to prevent the fall of Western Civilisation.

What a glorious mission! It looked like the Cult wasn't going to do anything for New Year. I thought maybe Dave Krash- he's the demagogue; the leader- had forgotten what the year was. Suited me fine, maybe I would get a chance to do something normal for New Year's. Then the day after Christmas I get a phone call. I pick it up, no-one is there. Exactly five minutes later the phone rings again, no-one there, five minutes later the same.

This is the Cult's "secret code" that a meeting was to take place that evening. Excessively paranoid if you ask me, did they think someone was tapping their phones? What government would waste resources on the likes of this obscure, tiny, cult?

So I, government spy, turn up to the meeting, and what do you know? It's all on. The Cult is going to meet at Armageddon and await the end of the world. Armageddon it turns out is an abandoned movie set in the Nevada desert, originally built for a western of the same name. The film was never made, the producers went bankrupt, but the set was left to weather in the desert. For some obscure reason The Magus, that's Krash's sidekick and the Cult's holy-man, has decided that this Hollywood Armageddon is the best place to await the Kingdom of God. I must admit it has a certain humour to it- but I am unconvinced of its mystical significance.

So, here I am on the way to Armageddon for New Years. I suspect the Pilgrims are going to try and do something weird, like kill themselves. It'll be Jim Jones in Jamestown all over again. Certainly I won't be drinking the soup. Anyway, if things totally go to shit I have a telephone number (and cell-phone) to ring for backup and a radio frequency I can also use. Backup will apparently take around two hours to arrive.

It is December 31, 1999.

CHARACTER SHEET: Jack Burroughs

Jack Burroughs is *agile and of above average intelligence*. He is *skilled in infiltration and has had weapons training*.

Equipment: Jack has a cell-phone and is armed with a Government .45, which has a seven round clip. He has two clips for the gun. Jack is dressed in a long coat, denim and boots.

Character Goals:

Jack wants to find out what the cult is up to, and disrupt it if it is Against The Law, particularly if it harms other people. Most importantly Jack wants to survive, so he will be very cautious about openly challenging the well-armed cultists.

Opinions:

Dave Krash: David is the leader of the Pilgrims to the Descended City. He is anti-Government and insane. Jack has seen David's Gulf War record. He, along with Kurt Thompson, were picked up, delusional and near starvation, in the Syrian Desert after a disastrous Special Forces mission.

Kurt Thompson: Another Gulf War veteran, he was shot in the head during the Gulf and only narrowly survived. Kurt is very loyal to Dave and carries a lot of weapons.

"The Magus": An insane old Indian who is the Pilgrim's holy man. Jack thinks that The Magus is insane.

Soviet: A young woman, with some strange socialist ideas. She acts as the cult's web-master.

Scenes and Personalities

There a number of scenes that may occur in the scenario, a branching timeline of these scenes is given below. In the timeline the dark arrows indicate the main sequence of scenes, the lighter arrows are possible diversions. The order is only approximate, the only definite sequence is that the first scene is the Arrival at Armageddon and the last is The Final Battle For Armageddon.

Timeline of Events

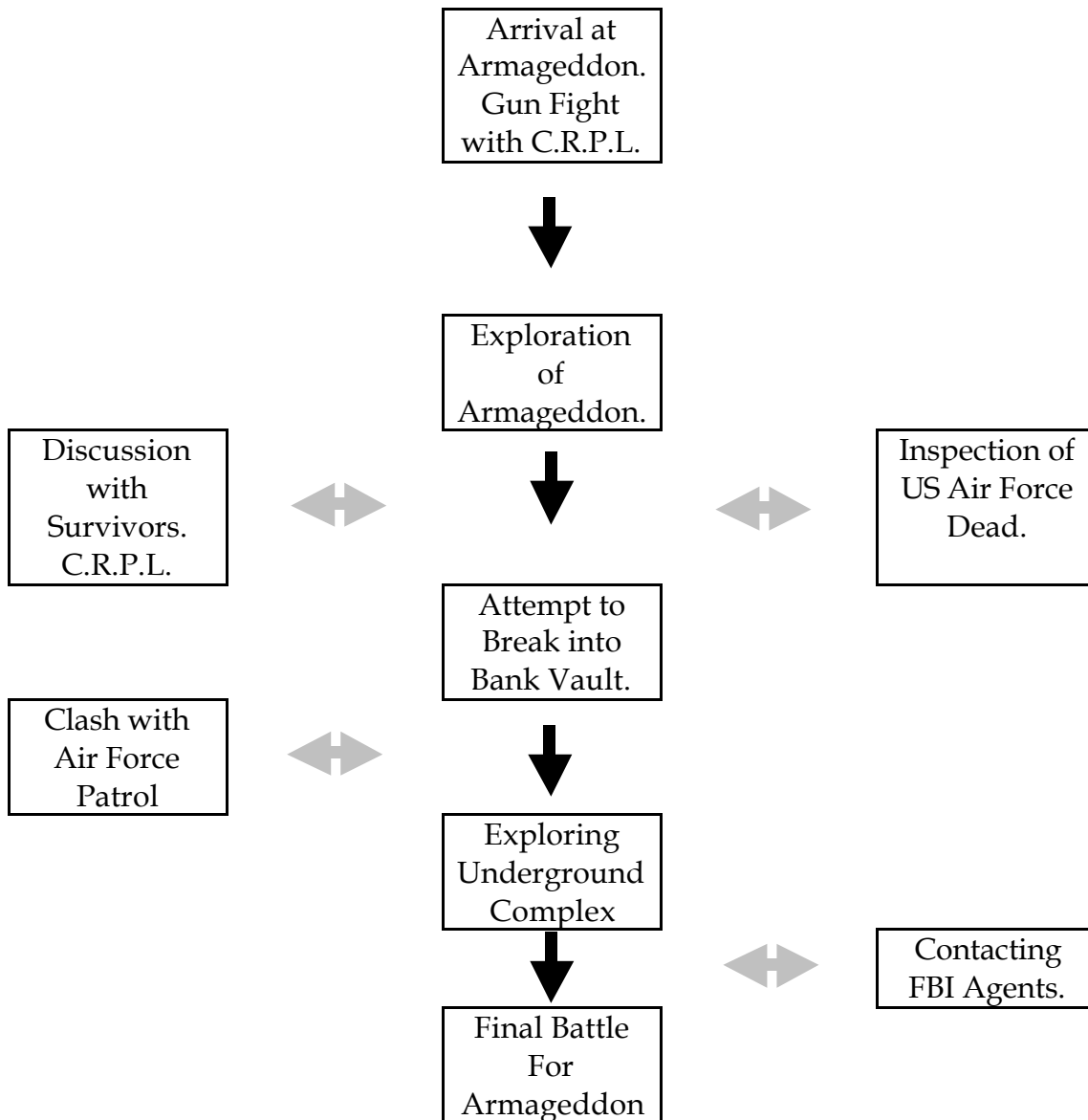

Arrival at Armageddon and Gun Fight With The C.R.P.L.

The Pilgrims arrive at Armageddon. The GM should have already described the appearance of the player characters and the other three Pilgrims. All the characters (the 5 PCs and 3 NPC Pilgrims) are travelling together in two vehicles to Armageddon. The GM should show the players the Road to Armageddon picture and the Town of Armageddon picture and describe the characters journey down the dusty highway to Armageddon, and their final approach driving their jeeps along the railroad tracks through the canyon.

As the players enter Armageddon it is late in the evening, about 10 O'clock at night, and only a couple of hours before the end of the world. The GM should hand out the map of Armageddon, and point out that there are a couple of vehicles (two pick-up trucks) parked in front of the Bank.

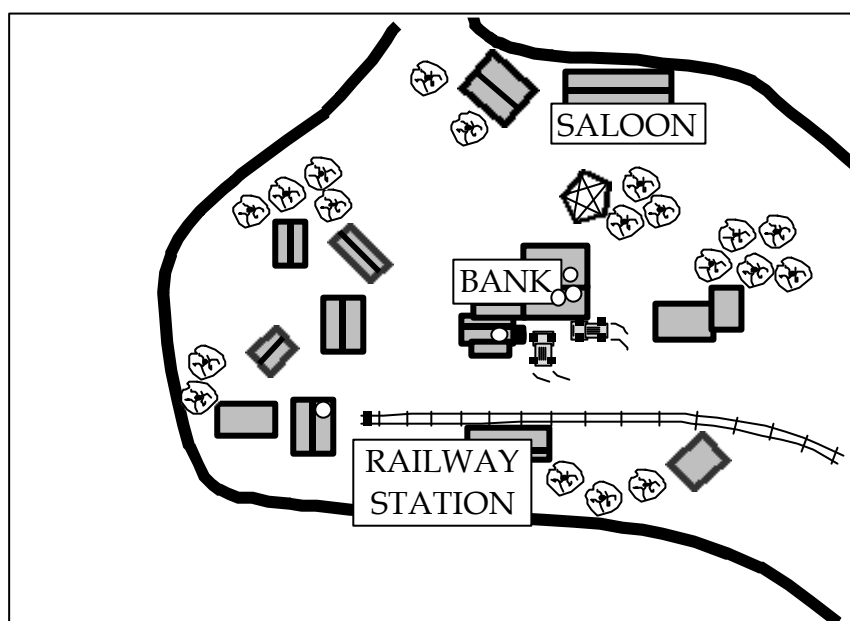

GM Map of Armageddon. White Circles indicate the positions of the C.R.P.L. The approximate location of the Magus' Ritual is also indicated by a pentagram (the GM should point this site out, secretly, to the player of the Magus).

The two pick-up trucks are those of the C.R.P.L (Cattle Ranchers Protection League). There are three C.R.P.L. members in the main part of the Bank (including Lil' May), one C.R.P.L. member in the raised construction next to the Bank and one C.R.P.L. member in the abandoned building near the end of the railway. The C.R.P.L. members have recently arrived and have shot the US Air Force guards (whose bodies are inside the Bank). When the characters arrive, the C.R.P.L. members in the Bank are getting organised to break into the Vault. The two C.R.P.L. members outside are armed with rifles and will attempt to snip at the characters, if they notice them. At the sound of gun-fire two of the C.R.P.L. members in the main part of the Bank (not Lil' May) will investigate.

The scene will probably proceed with the characters being sniped at by the C.R.P.L. members outside (which may kill one or more of the NPC pilgrims). The PC characters will probably return fire, ultimately killing the snipers. Meanwhile the C.R.P.L. members from inside the Bank will make their way outside, take cover behind their vehicles and exchange gunfire with the Pilgrims. They should also be despatched by the more heavily armed Pilgrims.

Possibly, at the sight of the two pick-up trucks the Pilgrims will decide to sneak into the town. This will be successful, but the C.R.P.L. snipers will notice anyone standing/driving in the streets, and fire upon them.

Probably, at the end of this scene, the C.R.P.L. members (except Lil' May) will be dead, one or more of the NPC pilgrims will be dead. The player characters should be alive, but may be wounded. If the player characters made a point of it (shooting to maim, for example) some C.R.P.L. members may have survived the gun-fight.

The C.R.P.L. members are all dressed as cattle ranchers (jeans, boots, jackets, cowboy hats) and have long rabbi-like beards. The attributes of the C.R.P.L. members are:

CHARACTER SHEET: C.R.P.L. members (Abraham, Jacob, Abel and Isaac)

The C.R.P.L. members *know guns*. They are *loyal to Lil' May*. They are *Fanatical in their Cause*.

Equipment: Abraham and Jacob (in the Bank with Lil' May) are each armed with Winchester 1901, 10 gauge Shotguns. The guns have 5 round magazines and they have 20 shells each. Abel and Isaac (Snipers) are each armed with Kentucky Long Rifles. These weapons do not have a magazine; Abel and Isaac each have 40 rounds on a bandolier.

Character Goals:

The C.R.P.L. members are attempting to break into the Bank Vault. C.R.P.L. is an anti-government, anti-corporate movement. They will attempt to attack the Pilgrims, believing them to be a government group.

Exploration of Armageddon

Following the gun-fight, the Pilgrims may attempt to explore Armageddon. They may do this in a group, or singly, either is fine. The major sites of interest are: The Bank, The Saloon and The Railway Station.

The Bank

The Foyer to the Bank has double doors that lead to outside, two teller windows that look into the Offices, a window to outside and a door into a hallway. The body of an Air Force Guard is lying in the room. He has been shot from close range, in the chest, with a shotgun. There is a single, wide

gauge rail track leading from the Railway Station, through the main door and towards the vault door (like which something heavy might be guided along).

The Hallway leads to another outside door, at the back of the Bank, two Offices and a Guard Post.

The Offices contain desks, filing cabinets, scales and papers. The papers are all blank and the filing cabinets empty. There is a lot of dust on the desks. One of the offices contains a window to outside.

The Guard Post contains a sophisticated looking military radio (which has been damaged by a shotgun blast, it is inoperable), a card table, with cards and chairs for two players, the body of an Air Force guard (also shot from close range with a shotgun), and a Bank Vault door. In this room is also Lil' May's vault breaking equipment (welding torch, explosives), and Lil' May herself, although she will attempt to flee out the back door if the Pilgrims enter the Bank. Lil' May might also venture outside to investigate what happened to the other C.R.P.L. members – particularly if a long time passes, or she heard a lot of gun fire. If they have not yet been killed or incapacitated elsewhere, Abraham and Jacob will be helping Lil' May set up her equipment.

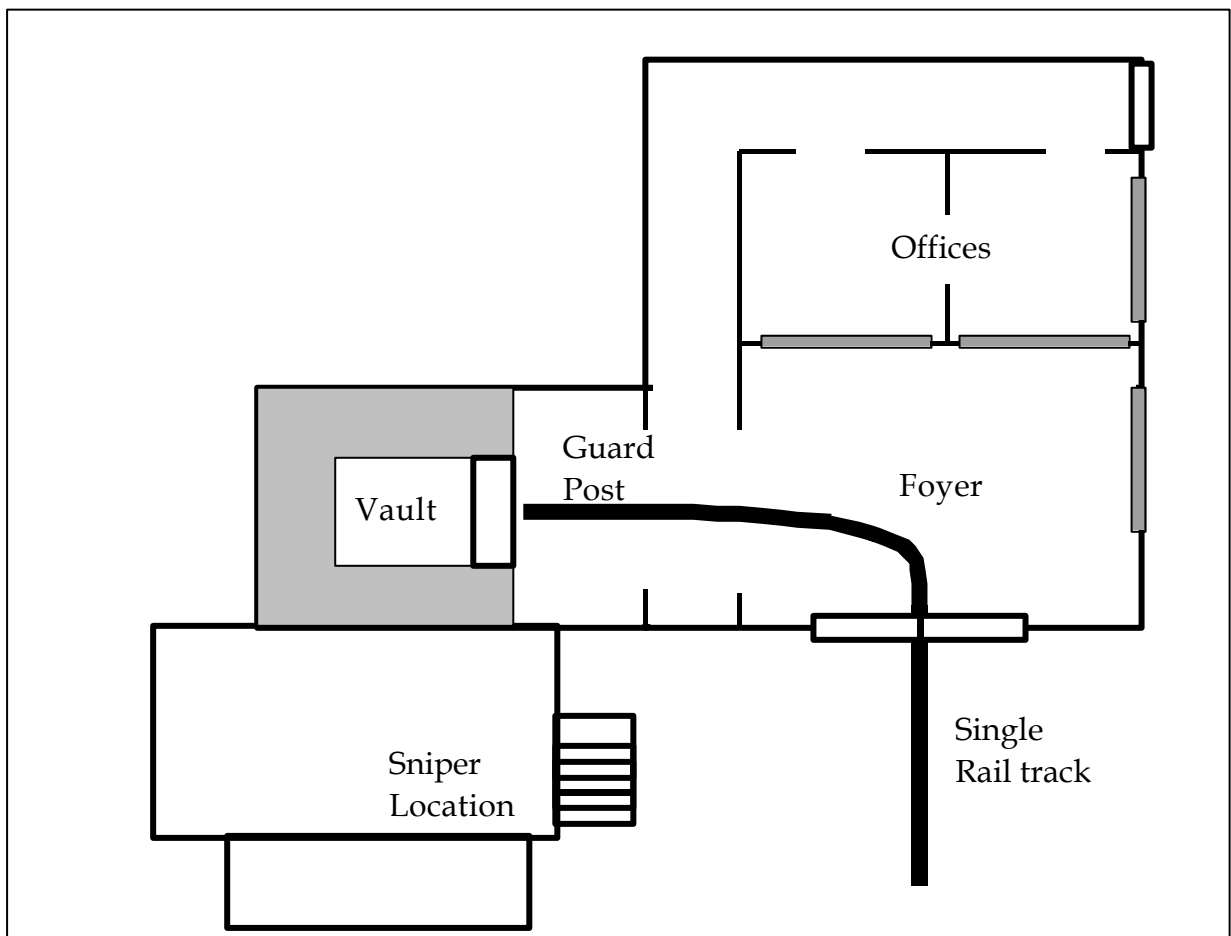

The Bank : GM Map.

The Vault, unlike the rest of the building is constructed of very thick reinforced concrete (with a wooden cladding outside). The vault door is massive and contains a security key-pad. It is locked. Inside, the Vault is empty, except for lift-controls- as the vault is really an elevator into the underground weapons cache.

The upper story to the Bank is a single empty room (remember this was a movie set), that has a few windows, no doors and no stairs. The only feature in the room is directly above the Vault, where there is a lift winch (within a concrete shell). There only access to the lift winch, is a ventilation grill (big enough to climb through if removed). A character inside the lift room cannot go anyway else, although they may be able to sabotage the lift. There is a US Air Force maintenance schedule in the lift room. The lift was last serviced three months ago is due for another servicing in two months time.

The adjoining raised room (which can be reached by an outside staircase) is where Abel (one of C.R.P.L. snipers) is based.

The Railway Station

The Railway station is an empty shell of a building, with three windows and a door. What is more interesting is the Railway track.

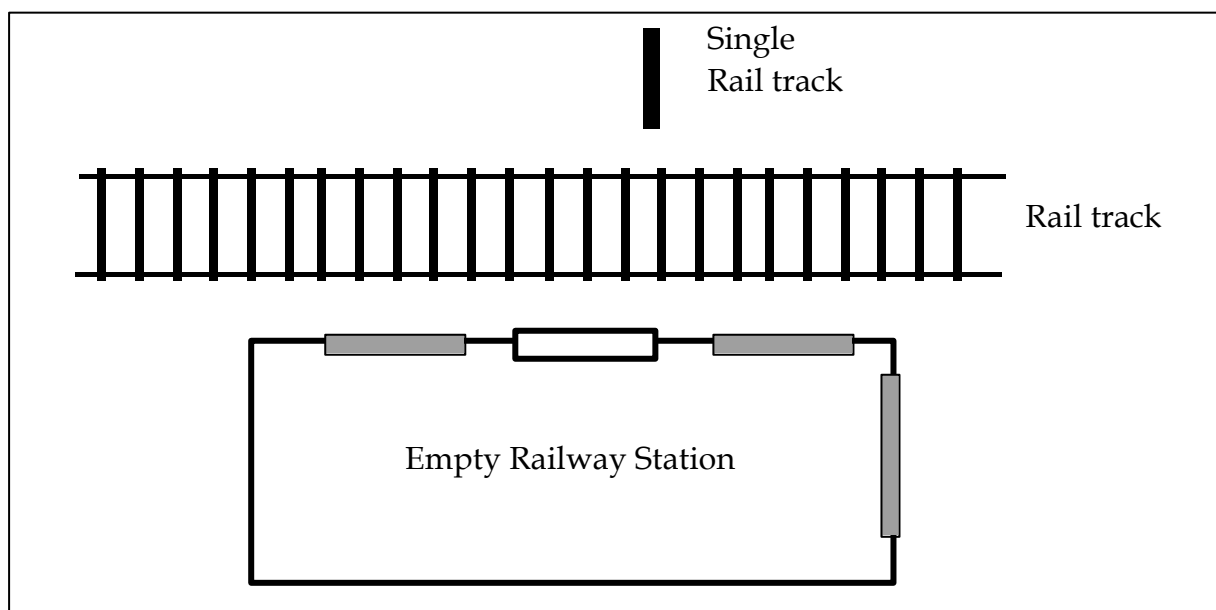

The Railway Station : GM Map.

If the characters inspect it, they will discover that the Railway track has been both recently (within the last month) and regularly used. There are both recent and old scratch marks on the track, and there is no brush growing onto the tracks. There is also a single, wide gauge track (also recently and regularly used) that leads from the Railway track to the Bank. Of course, although the characters have no way of determining this, this is because the

US Air Force is still using the underground weapons cache and occasionally it brings a train in to shuffle warheads between this cache and other caches elsewhere.

The Saloon

The other building of interest is The Saloon. The Saloon is set-up like an old-style Western Saloon, with swing doors, a bar, a piano, a pool table, a banister and rooms upstairs. What makes the Saloon interesting is that the bar is still wet (there are full kegs in the basement connected to the taps in the bar), and there are liquor bottles behind the bar. There is no cash register. There are various pendants, photographs and badges from US Air Force squadrons and divisions hanging in the Saloon. The ex-military characters (Dave and Kurt) may recognise that the pendants and badges range in date from the late 60s until today (1990s). Mostly they are from locally stationed (Colorado) units, but there are some from US units further away. There are no insignia from foreign military units. The Saloon is quite clean and the modern toilet facilities are white and spotless.

Clearly, (although not necessarily obvious to the player characters) the US Air Force elements responsible for guarding the area have been using the Saloon to throw the occasional party to entertain themselves and guests stationed here on exercise. Many of the photographs show drunken soldiers at Christmas and New Years celebrations.

The Air Vent

In amongst the group of three trees diagonally right of the Bank are two air-vents. The air vents are too small for a person to crawl down and each goes through a number of contortions (so they cannot be sighted down, nor can things be dropped through them). The vents exit into the power-plant room of the underground complex. Warm air blow out of one vent, air is drawn into the other.

Other Buildings

The other buildings in the town of Armageddon are empty shells. They have doors and windows, but nothing more. One or two are on the brink of collapse.

Discussions with C.R.P.L. Survivors

In the course of exploring Armageddon the characters may encounter C.R.P.L. survivors (which were not killed in the first scene). At the very least they will encounter Lil' May in the Bank. Lil' May is a small, blond woman (around 5' tall) in her early 30s. She is dressed as a cattle rancher. Assuming they do not kill her outright (which, probably, The Magus will not want to do – she is another possible sacrifice), the Pilgrims may question her about what is happening.

Lil' May is the leader of C.R.P.L. and she will be distraught at the death of her compatriots – particularly her brother Abel, and husband Jacob. Lil' May believes that the US military stores weapons in the Vault, which C.R.P.L. was

intending to capture to mount a campaign of terror against fast-food outlets state-wide. She is unlikely to explain this goal to the characters, and does not know the types of weapons stored. She will try to make out that one of the dead (Abel) was the leader of C.R.P.L. Lil' May will be afraid of the characters and will attempt to escape to fight another day.

Lil' May will, if pressed, explain that she and the menfolk are members of the Cattle Ranchers Protection League, which is a group set up to help farmers forced into poverty by multi-national beef farming corporations. Lil' May will tell the characters about the evils of fast-food companies who have forced the beef price so low that only large-scale corporate farms can afford to do business. This has destroyed many small farmers. If pressed this far, Lil' May might try to recruit any of the Pilgrims who seem interested – especially Soviet.

Other C.R.P.L. survivors do not have significantly different accounts to offer and will defer to Lil' May.

CHARACTER SHEET: Lil' May (C.R.P.L. leader)

Lil' May knows guns and blasting. She is fanatically anti-government and anti-corporate. Lil' May is quite intelligent. Lil' May is loyal to her menfolk.

Equipment: Lil' May is armed with a Colt 1873 .45 revolver. It has a chamber that holds 6 bullets. She has 12 bullets for it.

Character Goals:

Lil' May wants to destroy the fast-food industry. She was attempting to break into the Bank Vault, to recover the weapons inside. Her goal will rapidly change to escaping from the area with any surviving members of C.R.P.L.

Inspection of Dead US Air Force Personal.

Also in the course of exploring Armageddon the Pilgrims will discover the Air Force dead. There are two dead Air Force personal, both in The Bank. They are in their early 20s, have short military crew-cuts and are wearing combat fatigues and are both carrying (or at least have dropped) M-16A Assault Rifles (these are automatic weapons with 30 round clips and each soldier has three clips). An ex-military character (Dave or Kurt) will recognise the insignia they wear as that of a Colorado based Air Force military police unit. One soldier is wearing a corporal's insignia, the other a private's insignia.

The Attempt to Break into the Bank Vault.

The characters will probably attempt to finish the C.R.P.L. job of breaking into the Bank Vault. They should be able to achieve this. There are four obvious ways for them to proceed (although possibly the players may think of a plausible alternative):

- Blasting the door with the explosives provided by Lil' May. This will work, although it will require a character that knows what they are doing (Dave, Lil' May or, perhaps, Kurt). It will also take some time to organise.
- Firing a rocket (one of Kurt's) at the door/structure. This is unlikely to work, as shaped charges are really required. It will demolish the wooden Bank quite nicely though.
- Breaking the computer lock. Unlikely as it sounds, Soviet may attempt to circumvent the computerised locking system. This might work but it will take time. Cutting power will not work as the system is a) designed to fail locked, b) powered from an inaccessible cable coming up the underground shaft.
- The Magus can punch through the door (using his super-human strength). The Magus will probably not publicly attempt this.

If the characters access the lift winch system in the roof they may find it easier to blast through the roof of the Vault. This will irreparably damage the lift, probably plunging it down the shaft. A silent alarm is sounded when the Vault Door is opened. This will not occur if Soviet circumvents the lock, nor will it occur if the lift roof is blasted open. The alarm is based on the conductance of the door. The alarm will sound if the door is blasted open or a hole punched in it.

A Clash with an Air Force Patrol.

Exactly one hour after the characters arrive at Armageddon an Air Force patrol will arrive. The patrol will be in a Jeep and will arrive along the railroad tracks, as the Pilgrims did. The patrol has been dispatched because the guards at the lift door have not made a scheduled radio call. If the patrol does not immediately notice anything unusual (for example, Pilgrims, bodies in the street, explosions, abandoned pick-up trucks) they will park their Jeep outside the Bank and make their way inside. Where, presumably, they will notice something unusual.

As soon as they do notice something unusual the patrol will (make their way back to their jeep if they are not already in it and) radio back to base for backup. The patrol will then withdraw to a safe position, observe and await their backup.

It is possible, if, for example, all the Pilgrims are indoors and the patrol immediately realises that something is wrong, that the Pilgrims will not observe the arrival of the patrol. The patrol's backup will arrive in half an hour to an hour, in helicopter gun-ships (this is The Final Battle For Armageddon).

If the Pilgrims do (somehow) prevent the patrol from calling for backup then the helicopter gun-ships will arrive in an hours time instead (as, eventually, the patrol will be reported missing, too). This will not happen if the Pilgrims

fake an “all-is-well” report, although it is unclear how the player characters could manage this.

CHARACTER SHEET: Air Force Patrol (3 Members)

The Air Force patrol members have *the ability to use and maintain personal military weapons and systems*. They have *above average constitutions*.

Equipment: The soldiers are wearing combat fatigues and are carrying M-16A Assault Rifles (these are automatic weapons with 30 round clips and each soldier has three clips).

Character Goals:

The Air Force Patrol members are investigating the radio silence. They do not want to engage in a gun-fight with lunatics.

Exploring the Underground Complex.

Beyond the Vault door is a lift. The lift shaft leads down four stories (around 12 m). The lift shaft opens into an airlock. All the rooms in the complex are connected by airlocks. The airlocks have large bulkhead doors, like in a ship or submarine. All the doors are unlocked, but shut. It is an easy task to open them. All the rooms (including airlocks) have an intercom system. There are light switches in each room, connected to overhead fluorescent lights. All lights are initially turned off, but function when turned on. The walls and ceilings of all the rooms are made of clean, white tiles. The floors are made of grey concrete. A single, wide gauge rail track runs through parts of the complex (marked in grey on the map).

On the other side of the first airlock is a security station (which contains only a desk and a chair) and another airlock door.

The important rooms of the complex are a laboratory, a power-plant and a weapons hall. (to give an idea of scale the weapon hall is around 5 m by 10 m in area).

The laboratory contains scientific equipment (HPLC, centrifuge, autoclaves, incubators, imaging equipment, computers). All the equipment is in storage. The computing and lab equipment is around one to five years old. None of the computers work (they are all missing hard disk drives). There are one dozen environmental suits in storage in the laboratory. There is no written material in the room except safety and packaging labels. There are two cool stores attached to the room. Both are off and contain no samples.

The power-plant contains a thermal electric generator (which is driven off temperature difference between its location and a sink- a long shaft that goes deep underground). It is powering ventilation and cooling systems and the lighting in the complex. A maintenance schedule on the wall beside it

indicates it was last serviced, by US Air Force machine shop, three months ago and is due for another servicing in two months time.

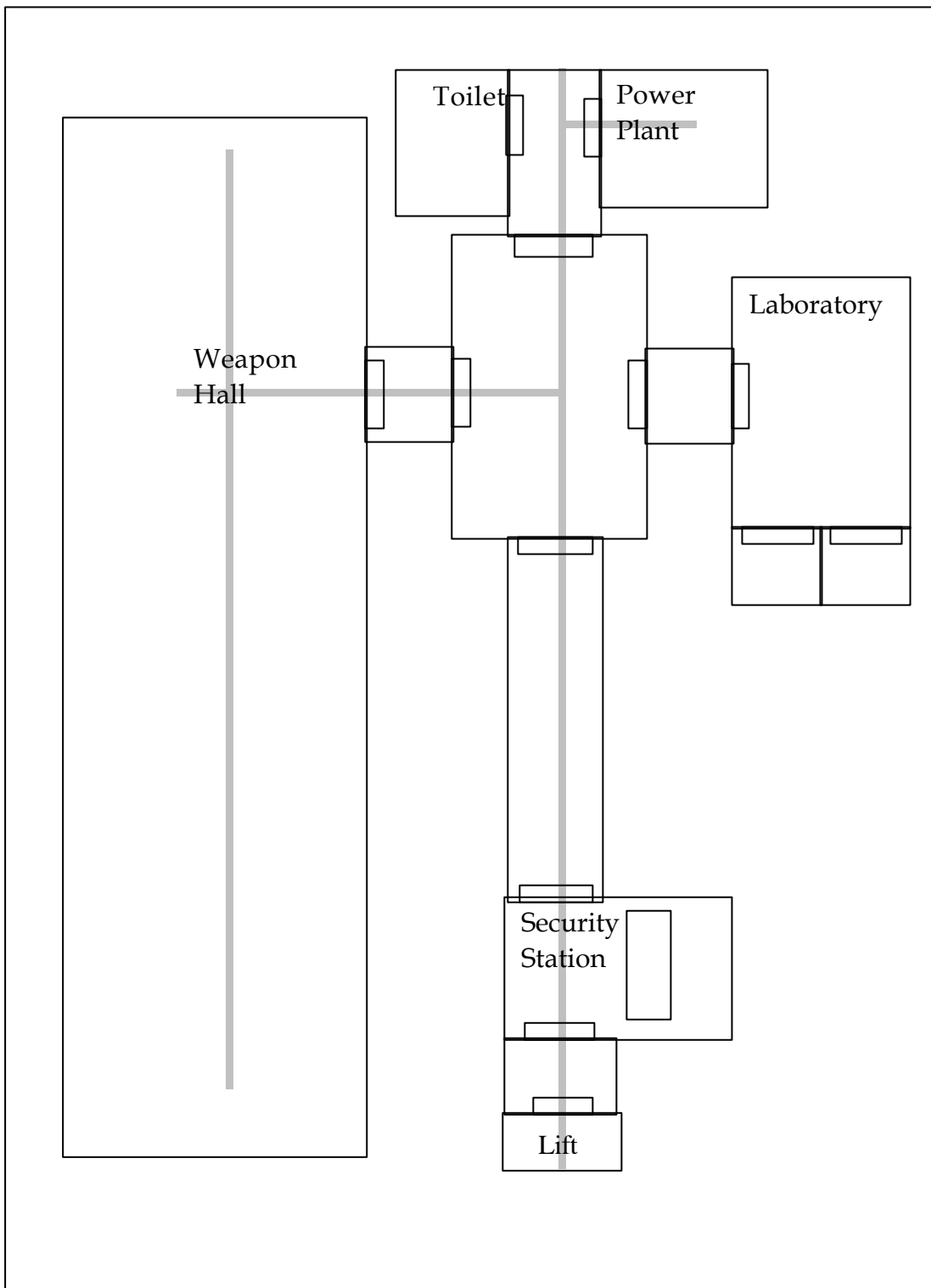

The Underground Complex : GM Map

The weapon hall contains a lot of warheads. The hall is cooled (to around -15°C). The warheads are kept on racks, and are in a variety of sizes. There seem to be two types of warheads in storage. One sort of warhead is shaped like a

cone and has a screw-thread on the bottom (presumably for attaching to a missile). These warheads are large (up to 1 m in diameter). The other sort are long cylinders topped by a stubby cone that has a sparger (like a shower head) set into it. The cylinders are around 2 m long and 20 cm in diameter.

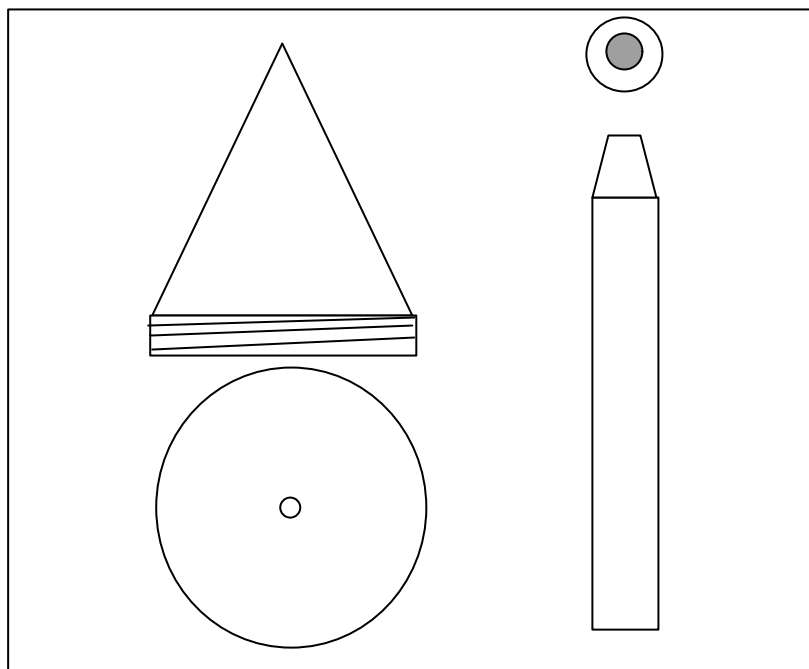

Warheads : GM Diagram

There are two trolleys in the weapon hall, which can be run on the single, wide-gauge railway track. The warheads all contain weaponised small pox. It will be difficult (but not impossible) for the characters to dismantle them, if they do so, they will be infected with a small pox variant (unless wearing environmental suits, for example).

How Small Pox Can Ruin Your Day

The variant of small pox that the warheads contain is very virulent and lethal, although its time scales are too long to be of much significance for the scenario. From around an hour after infection the patient becomes infectious, themselves. Infection primarily occurs through the infected breath of the patient, but it may also be spread through skin contact. Around a day after infection the patient begins to exhibit a high fever and a pink rash. Not long afterwards a severe pain cripples the patient, which continues for a number of days, during which the patient will likely die. If the patient survives this period, they will recover, and the pink rash will form scabs that fall off over time creating scars. The patient remains infectious for a number of days after the initial infection.

Contacting the FBI Agents.

The Jack Burroughs character may try to contact his FBI superiors at some point. If he manages to and the situation he describes sounds dire enough, they will send reinforcements. They will not, however, arrive for many hours

(long after the scenario is finished). They will contact the local military authorities.

The Final Battle For Armageddon.

The Final Battle begins when the US Air Force reinforcements arrive. They have been either summoned by the Air Force patrol, or have come to investigate the missing patrol, or been alerted by the FBI, or been alerted by a break-in into the underground complex. The Air Force arrives a few minutes to midnight, just as the world begins to end.

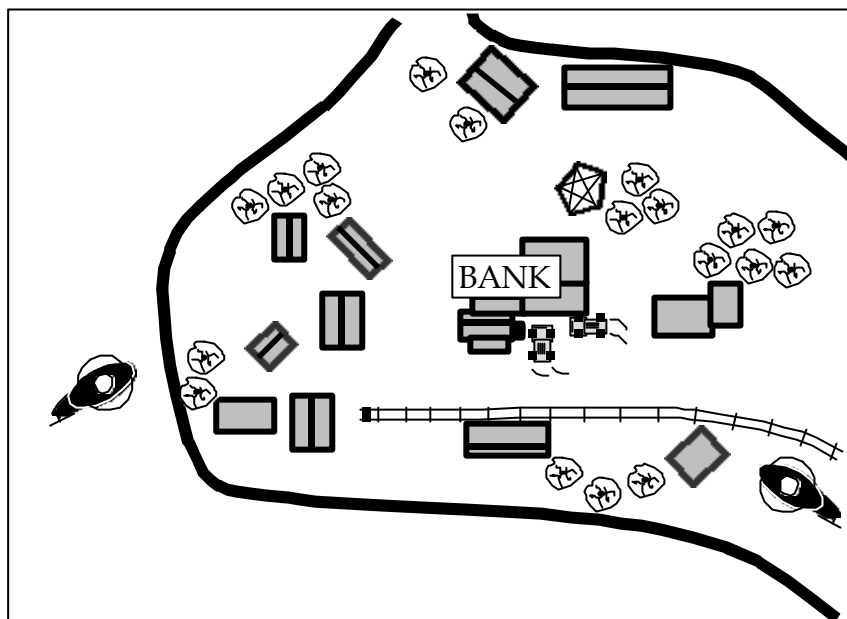

The End of The World : GM Map. Indicating Helicopter Approaches and Sacrifice Site.

The Air Force arrives in two black-hawk helicopters, indicated on the map. The one arriving up the railroad will drop off a squad of 15 soldiers who will approach on foot. The 15 soldiers are armed identically to the Air Force patrol, with the addition of concussion grenades and combat-environmental suits. The other helicopter (arriving over the ridge) will drop a couple of snipers off onto the ridge (armed with high velocity rifles). Both helicopters will hover at the approximately indicated locations and fire rockets and mini-guns at anything hostile. The 15 soldiers will approach the Bank on foot and attempt to secure the underground complex.

It is likely that the player characters will be in or near the underground complex when the air force arrives. Possibly, the first they will notice is when soldiers make their way into the complex.

There are a couple of ways this scene can end. None of them particularly good, for the characters. If the characters surrender then they will probably not be shot, but will be rounded up (and the scenario ends). If the characters fight, then the government forces will almost certainly kill them. An

exception is Jack Burroughs, who may be spared, if he has contacted his superiors and he identifies himself in some way to the military.

CHARACTER SHEET: Air Force Assault Team (15 Members)

The Air Force patrol members have *the ability to use and maintain personal military weapons and systems*. They have *above average constitutions*. They are *well trained*.

Equipment: The soldiers are wearing combat fatigues and are carrying M-16A Assault Rifles (these are automatic weapons with 30 round clips and each soldier has three clips). Each soldier also carries three concussion grenades and is wearing an environmental suit.

Character Goals:

The Air Force Assault Team are attempting to eliminate the terrorist elements who have captured a dangerous military weapon depot.

Another exception to inevitable character extinction is The Magus, who is invulnerable to mortal weapons. The Magus will, presumably, try to make his way to the sacrifice site. He will have to bring either Soviet or Lil' May with him, shielding her somehow from the weapons. If he manages to kill her, at the site, at the correct time, then darkness will envelop the moon and the stars, the winds will cease to blow and the world will end...

The End

That's all. Ideally, the scenario should end with The Magus' sacrifice, so as GM be lenient on the "correct site, correct time" element.

Have fun with the scenario. And the author *is* aware that the millennium began in 2001.

The following section contains a map for the players and a couple of photographs of Armageddon. The maps and photographs are not quite consistent, but they should give an impression of what the town is like to the players.

Resources

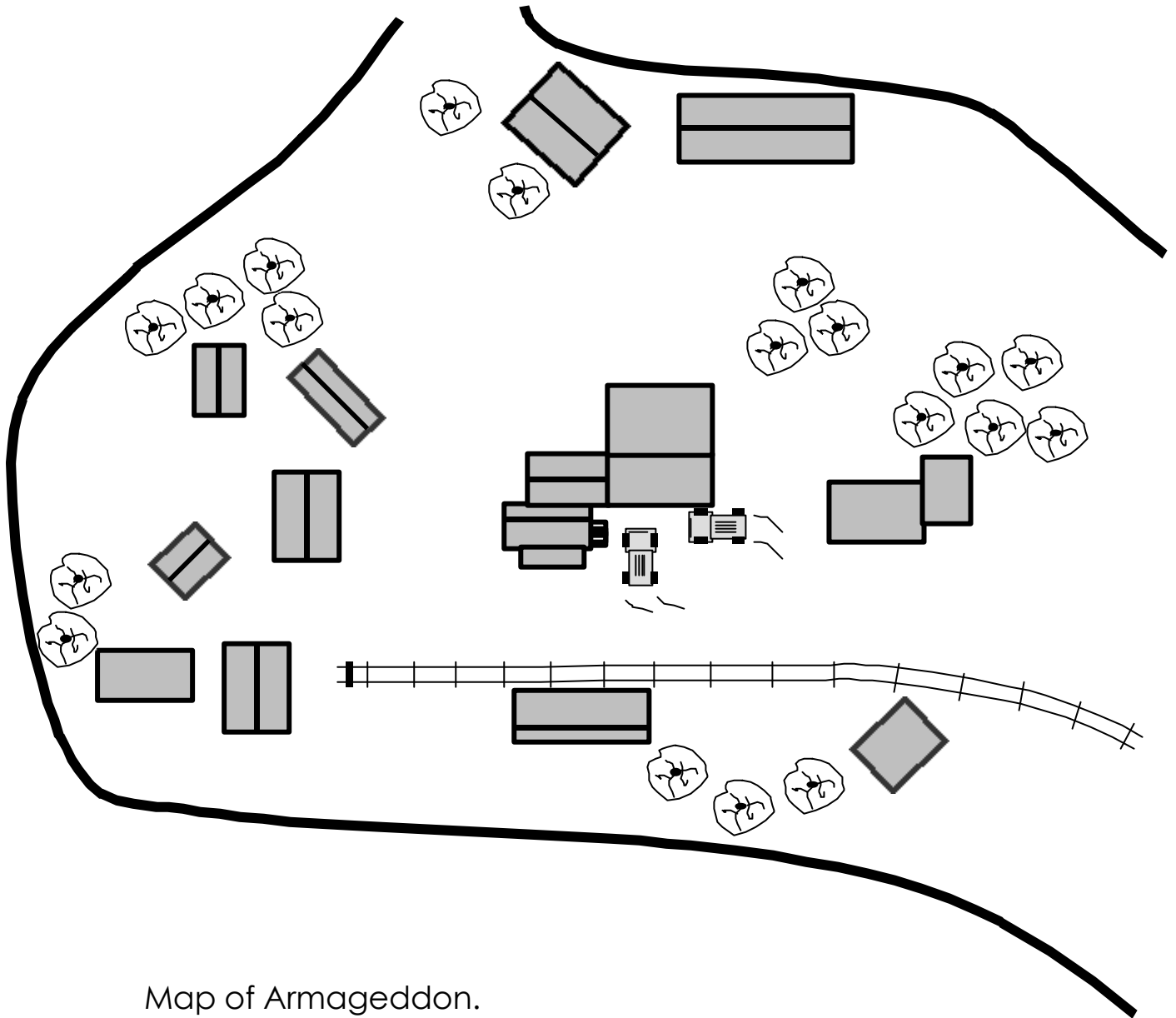

Map of Armageddon.

The Town of Armageddon.



The Road to Armageddon.

